

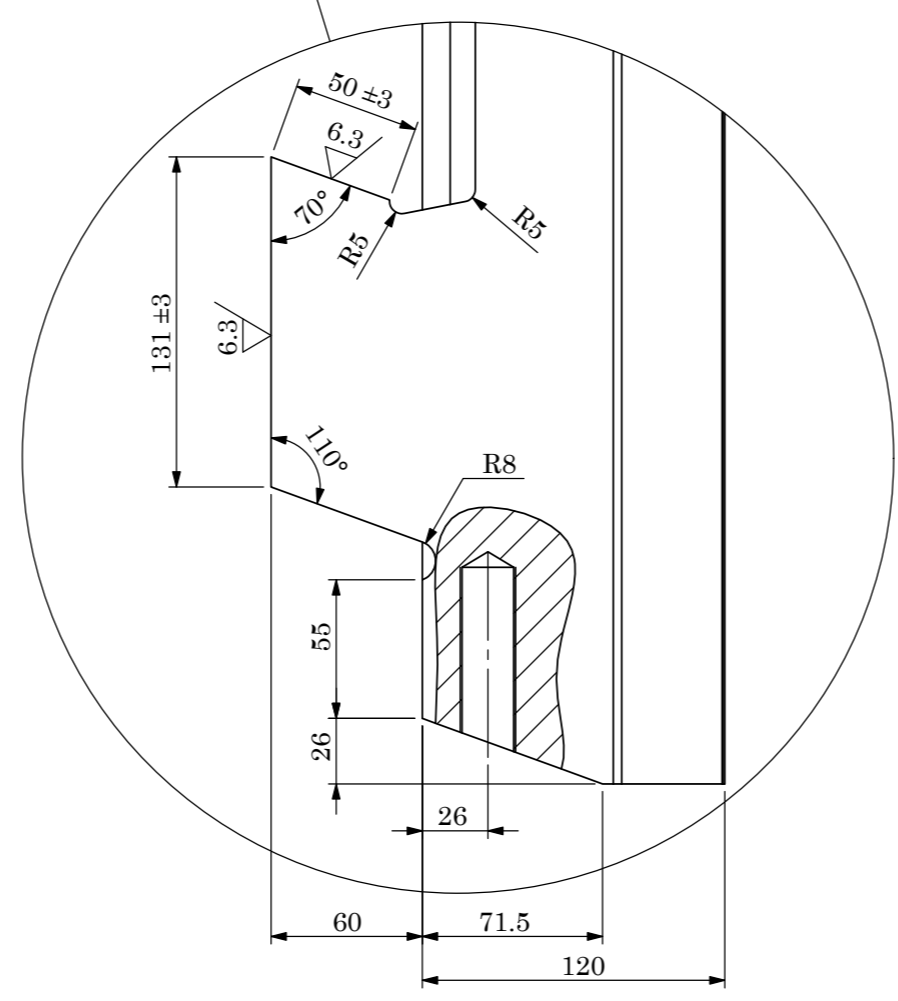

DETAIL B  
SCALE 1 : 3

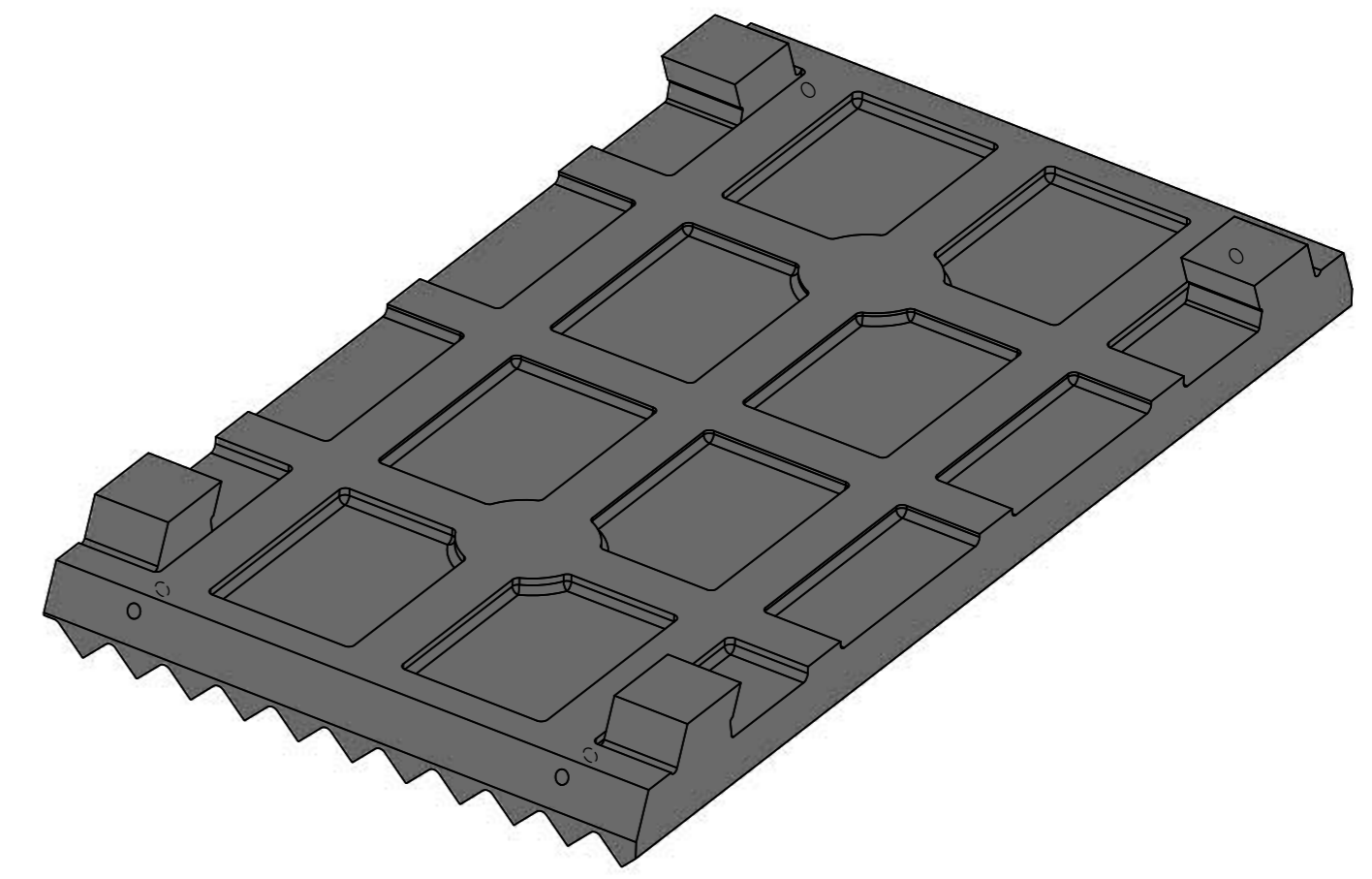

DETAIL A  
SCALE 1 : 3



UNLESS OTHERWISE SPECIFIED: DIMENSIONS ARE IN MILLIMETERS SURFACE FINISH: TOLERANCES: LINEAR: ANGULAR:		FINISH:	DEBURR AND BREAK SHARP EDGES	 <b>دفتر فنی و برنامه ریزی</b> <b>شرکت سیمان سفید ساوه</b>	
NAME	سعيد توکلی	CHKD	يوسف گرجي	ITEM: 10-32	TITLE:
DATE	۹۷/۰۷/۱۹	STORAGE CODE:	21103210118	MODEL STORAGE CODE:	25531113114
SIGNATURE		REVISION:		MATERIAL:	1.3401+ (0.3~0.5)% Mo+(1.5~2)% Cr
		QUANTITY:	2	WEIGHT(kg):	1300
		SCALE:	1:10	DRAWING NO.:	SWC.T-0001
				DROWING Ref.:	3C.5871 (Item: 401) SLMD 01032001
				SHEET 1 OF 1	A2